

TWISEAL

is made out a transparent plastic body with a rotating core. Inserted wire rotate around the core for sealing. Once sealed, tab is broken to secure asset.

Material

- Polycarbonate, Polyacetal

Marking

- Laser marking
- Customize name/logo
- Sequential numbering
- Laser barcoding

Application

- Meters
- Measuring machines
- Security boxes
- Gaming machines



Product Code	Dimension					Packaging		
	Total Length, TOL (mm)	Width, W (mm)	Thickness, T (mm)	Tag Length, TL (mm)	Tag Width, TW (mm)	Quantity per box (pieces)	Weight per box (kg)	Box Dimension, L x W x H (mm)
TWI	60.5	14.0	1.4	30.1	12.2	1000	2.9	428 X 184 X 128
TWI(WP)	60.5	14.0	1.4	30.1	12.2	1000	3.8	480 X 187 X 134

Note : WP – White Patch/ Tag

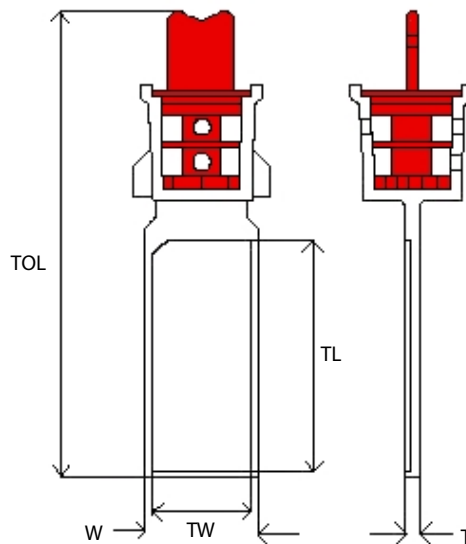

" A S SEAL SECURE YOUR ASSETS "

